

WARNING

- Risk of fire or electric shock.
- Disconnect all power before installing or servicing.
- Installation Instruction for qualified electricians only.
- Install per National Electrical Code and local regulations.
- Read Installation Instructions completely before installation.
- Failure to follow Installation Instructions may void warranties.

To reduce risk of electric shock turn off the electrical supply before installing or servicing the light fixtures and driver. Failure to do so may result in serious injury and/or damage to the components.

AVERTISSEMENT

- Risque d'incendie ou d'électrocution.
- Débranchez toute alimentation avant l'installation ou entretien.
- Installer conformément au code CE et aux réglementations locales.
- Lire les instructions d'installation complètement avant l'installation.
- Le non-respect des instructions d'installation peut annuler les garanties.

Pour réduire le risque de choc électrique, coupez l'alimentation électrique avant d'installer ou de réparer les luminaires et l'alimentation électrique. Le non-respect de cette consigne peut entraîner des blessures graves et / ou endommager les composants.

THIS PRODUCT MUST BE INSTALLED IN ACCORDANCE WITH THE APPLICABLE INSTALLATION CODE BY A PERSON FAMILIAR WITH THE CONSTRUCTION AND OPERATION OF THE PRODUCT AND THE HAZARDS INVOLVED

CE PRODUIT DOIT ÊTRE INSTALLÉ SELON LE CODE D'INSTALLATION PERTINENT, PAR UNE PERSONNE QUI CONNAÎT BIEN LES PRODUIT ET SON FONCTIONNEMENT AINSI QUE LES RISQUES INHÉRENTS

The light source contained in this luminaire shall only be replaced by the manufacturer or the service agent or a similar qualified person.

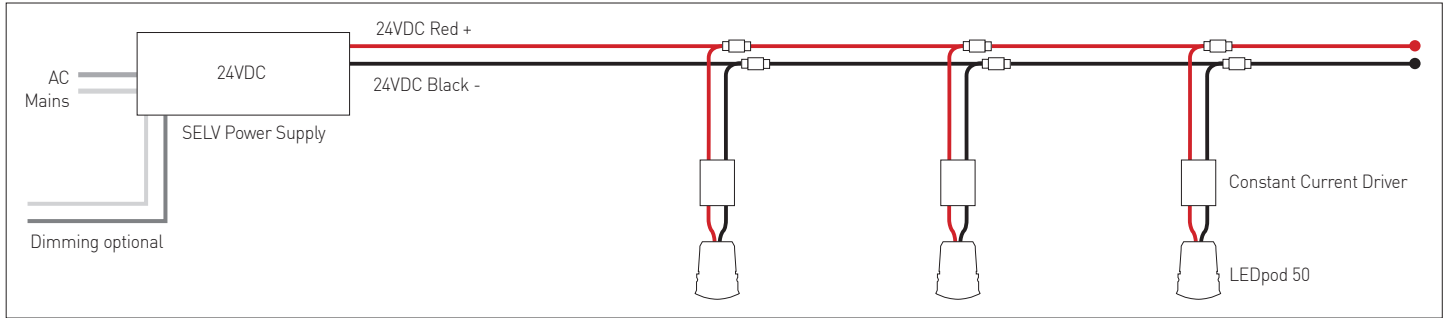

LEDpod Removal Steps

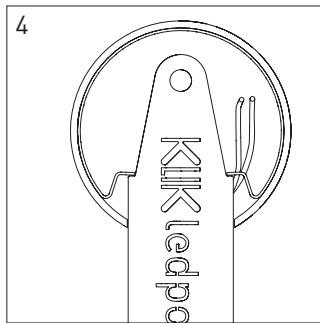
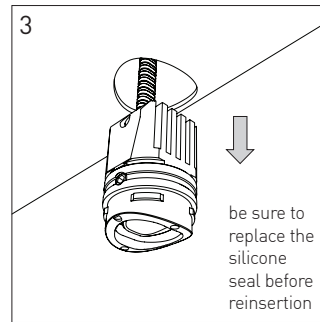
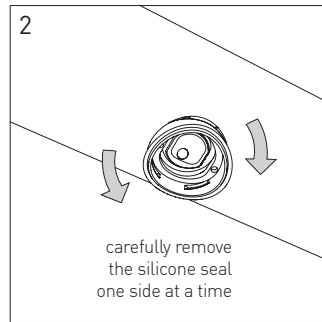
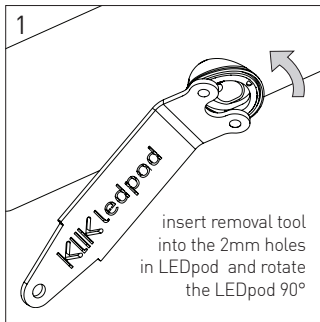

WARNING

- Risk of fire or electric shock.
- Disconnect all power before installing or servicing.
- Installation Instruction for qualified electricians only.
- Install per National Electrical Code and local regulations.
- Read Installation Instructions completely before installation.
- Failure to follow Installation Instructions may void warranties.

To reduce risk of electric shock turn off the electrical supply before installing or servicing light fixtures and driver. Failure to follow Installation Instructions may void warranties.

AVERTISSEMENT

- Risque d'incendie ou d'électrocution.
- Débranchez toute alimentation avant l'installation ou entretien.
- Installer conformément au code CE et aux réglementations locales.
- Lire les instructions d'installation complètement avant l'installation.
- Le non-respect des instructions d'installation peut annuler les garanties.

Pour réduire le risque de choc électrique, coupez l'alimentation électrique avant d'installer ou de réparer les luminaires et l'alimentation électrique. Le non-respect de cette consigne peut entraîner des blessures graves et / ou endommager les composants.

THIS PRODUCT MUST BE INSTALLED IN ACCORDANCE WITH THE APPLICABLE INSTALLATION CODE BY A PERSON FAMILIAR WITH THE CONSTRUCTION AND OPERATION OF THE PRODUCT AND THE HAZARDS INVOLVED

CE PRODUIT DOIT ÊTRE INSTALLÉ SELON LE CODE D'INSTALLATION PERTINENT, PAR UNE PERSONNE QUI CONNAÎT BIEN LES PRODUIT ET SON FONCTIONNEMENT AINSI QUE LES RISQUES INHÉRENTS

The light source contained in this luminaire shall only be replaced by the manufacturer or the service agent or a similar qualified person.